

# 3-Channel U.S. Navy Blimp® Instruction Manual

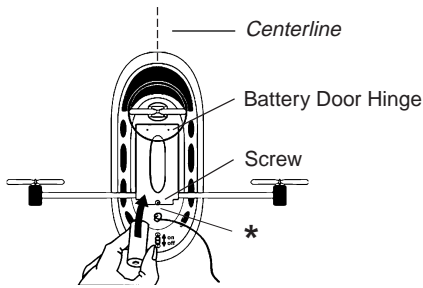

**Diagram #1** - Installing the CR123A Battery into the Thruster Engines Module.  
\* Note where the Ballast Putty can be placed.

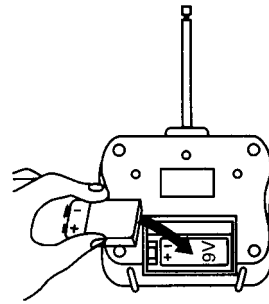

**Diagram #2** - Installing the 6F22 (standard 9V Battery) into the Remote Controller.

**Your kit includes:**

1. Metallized inflatable balloon
2. Thruster Engines Module
3. Remote-Controller with Antenna
4. Putty (for balancing/ballast)
5. Rudder Fins

**You also need (not included):**

1. 1 Battery CR123A (3V Lithium battery) - for the Thruster Engines Module.
2. 1 Battery 6F22 (9V Alkaline battery) - for the Remote-Controller (R/C).
3. Helium gas for the balloon. Purchase helium from florists, party shops, or any other shop selling balloons.
4. Single and double-sided tape to attach gondola and fins to balloon.

**INDOOR USE ONLY! THE BALLOON IS EQUIPPED FOR INDOOR USE ONLY! MANUFACTURER IS NOT RESPONSIBLE FOR ANY LOSS OR DAMAGE TO THE BALLOON THAT MAY OCCUR IF BALLOON IS USED OUTDOORS.**

**PREPARING BALLOON FOR FLIGHT!**

**1. Battery for the Module**

Insert battery type CR123A in the Thruster Engines Module's battery compartment by opening the screw of the compartment's door (Diagram #1). Check that the battery is properly installed by switching the ON/OFF switch (on the module) to the ON position. Close the battery door, tighten the screw and switch to OFF.

**2. Battery for the Remote Controller**

Insert a 9V battery into the R/C's battery compartment (Diagram #2).

**3. Helium for the balloon**

Insert the helium tank nozzle into the Auto-Seal Valve in the back, along the seam of the balloon. Be careful not to push the nozzle too deep as it may damage the balloon's Auto-Seal Valve. Fill the balloon with helium until the balloon becomes firm without over-stressing the seams. To close the valve, press the Auto-Seal Valve back together and it will not leak.

**WARNING!**

- Be careful. HOLD THE BALLOON SECURELY after it is filled up because the balloon could fly away!
- Do not continue to fill the balloon after it gets firm because it could burst.
- The balloon expands when temperature rises. If you completely fill the balloon at a cold temperature and the room temperature increases, the balloon may rupture or burst.

**4. Connect the Thruster Engines Module (Refer to Diagrams #4 & #5)**

- Apply double-sided tape to the bottom of the Module on the flat contact area. Push and secure the module to the underside of the blimp. Once module is secured, apply single-sided tape to fasten the outside flange to the blimp.
- You may find it easiest to hold helium-filled airship with one arm while pressing the taped module to the bottom center of the balloon. Another option is place and press the taped module to the bottom of the balloon while pushing it against the ceiling.
- The correct direction of the module is when the ON/OFF switch faces the back of the balloon. (The valve tag should be at back - refer to Diagram #4).
- Release the antenna wire to let it hang loose and free from obstructing the propellers.

**NOTE:** As placing the module in the proper balanced position may take a few attempts, remove it by very carefully peeling the module away from the balloon. Take note as to how the balloon acts with the weight - *Nose heavy* - place slightly back. *Tail heavy* - place slightly toward the front. Make sure the module is aligned straight

**WARNING!**

- The Thruster Engines Module should be handled carefully. It is made from very light materials that can be easily damaged by rough handling or if dropped onto the floor.

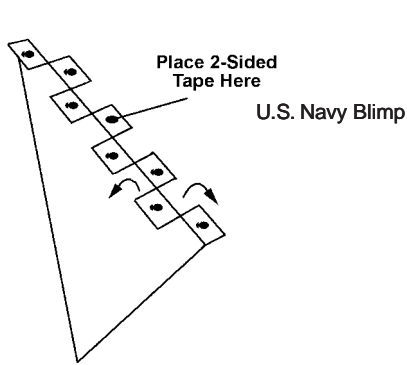

**Diagram #3** - Alternate bending tabs left, then right / Applying 2-Sided tape to folded Rudder Fin Tabs.

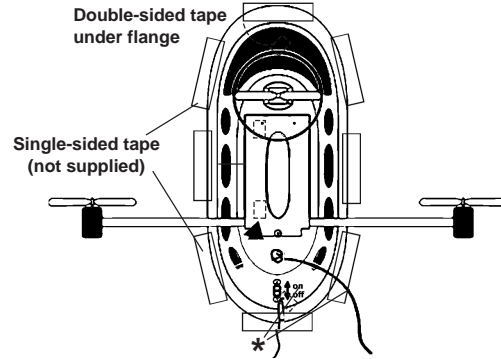

**Diagram #4** - Placement of Thruster Engines Module on balloon.

**NOTE:**

Invent competitions such as knocking over targets, steering through courses, time lapse racing or even hone your skills trying to pick up light objects by placing a small paper clip on the end of the antenna wire and using it as a hook (You may have to adjust the Ballast Putty to make up for the extra weight). Try delivering the object to a drop-off zone!

**BE SAFE & HAVE FUN!**

Email us with some of your ideas, stories and questions! We would love to hear them!  
info@interactivetoy.com

**FCC Note: (United States Only)**

This device complies with Part 15 of the FCC Rules. Operation is subject to the following two conditions:  
(1) This device may not cause harmful interference and  
(2) This device must accept any interference received, including interference that may cause undesired operation.

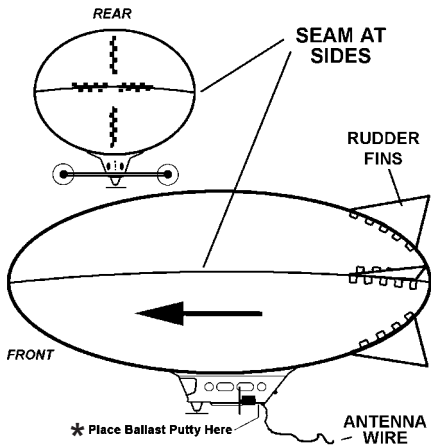

**Diagram #5** - Placement of Thruster Engines Module & Rudder Fins.  
\* Note where the Ballast Putty can be placed.

# 3-Channel U.S. Navy Blimp® Instruction Manual

## 5. Connect Styrofoam Fins

Carefully separate the Styrofoam into the 4 fins following the perforated lines. Each fin has one edge with tabs that need to be separated. Bend each tab by 90° - The first tab to the left and the next to the right - continue to alternate to the end (Diagram #3). Attach fins to the tail of the Blimp by using double-sided or regular Scotch tape (Diagram #5). *Ensure Fins are straight!*

## 6. Balance the Balloon in the air (adjusting the 'Ballast' putty) (\* Diagram # 1, 4, 5)

Make sure that you are indoors, far from any ventilator, air-conditioner outlet or any other source of wind. Carefully allow the weight of the Module to roll the balloon upright, so the Module is positioned (hanging) underneath. Slowly release the balloon and check its movement:

- If the balloon floats up - place a small piece of putty along centerline of Module.

### Tip!

Placing putty on the module can easily be done by pressed gently. The putty sticks well to any surface. If placing putty *off* the center line (center, front to back), balance evenly by placing equal amounts on either side of module. Keep putty away from turning propellers.

- If the balloon sinks down with the putty - remove some of the putty.
- If the balloon sinks down WITHOUT ANY putty - carefully add some more helium into the balloon (not too much, balloon can burst). Adjust & Repeat until the balloon suspends in the air when released. If problem persists, try refilling balloon with fresh helium.

*For the best flying performance the balloon needs to be in a neutral, balanced position, with a slight rise - Suspended in mid-air - ensure there is NO CONTACT with any surrounding items.*

### Important!

The balloon stays filled up for approximately 1-2 weeks. Helium will slowly dissipate - which is normal. The balloon will begin to sink to the floor. Add a small amount of helium in the balloon's reusable sealer (as described in step 3). Repeat the ballast adjustments in step #6 afterwards.

## 7. Operating your blimp

- Turn the Thruster Engines Module's switch to the 'ON' position
- Screw the antenna into Remote-Controller (R/C) until it is secure.
- Hold the R/C in your hands, and follow the instructions that are printed on the R/C.

### Tip!

For best performance of the R/C - use short bursts of the engines (push and release) of 1-3 seconds. This will also save the battery power for longer use. Experiment with directional control & timing to navigate the vessel as desired. Develop your own skills and techniques! *Hint: Forwards UP, backwards DOWN!*

## 8. Cautions for Handling your Blimp

- Do not use the balloon outdoors - the slightest breeze could blow the balloon away.
- Do not fly the balloon near sharp or pointed objects. If the balloon repeatedly bumps into sharp or pointed objects, it will damage the balloon and helium gas will leak even though a hole is not apparent.
- Do not fly the balloon near people, especially children and pets.
- Do not operate the balloon near people's face or hair. This is very dangerous because the propellers are constantly turning. If the balloon gets near someone's face or hair, STOP operating the controller, which will stop the propellers from moving.
- The balloon may conduct electricity, which may cause harm or injury. The customer is completely responsible for the control and safety of the balloon.
- Control and navigation will be compromised if operating the balloon near a ventilator, air conditioner outlet or any other source of wind. AVOID ROOMS WITH CEILING FANS!!
- Do not fly the balloon near any source of heat (Halogen lights, candles, ovens, heat radiators, etc.). This will damage the balloon.
- When balloon is not in use, leave it inflated inside a cool, dry room with closed windows and doors.

### Tip!

The module's hanging antenna wire can be carefully used as an anchor to tie the balloon to a fixed object in a room (a 'mooring' in balloon jargon!).

- Do not store the balloon in an area where there is a temperature variance of more than 10°. Such an increase in temperature will cause the balloon to enlarge. If this occurs, in an extreme case, carefully open the Auto-Seal Valve to release a small amount of helium.. by carefully inserting a drinking straw. Remove a small amount and reseal immediately.
- Rooms with windows and direct sunlight may create more than a 10° indoor temperature variance between morning and night. This would NOT be an ideal storage area.
- The purity of the helium will decrease if air mixes with the helium. If this occurs, deflate the balloon and refill with new helium.
- Do not forget to turn the Thruster Engines Module switch to OFF when you are finished playing with the balloon.
- Do not touch the inside of the receiver or the transmitter with your hand or with a metal object.
- When storing the balloon for a long time period -
  - Remove the module from the balloon by carefully peeling off the tape. (Refer to Step #4's NOTE regarding removal of module. Also, be careful and hold on to the Balloon so it can't float away!)
  - Remove all batteries - from both the R/C and module.
  - Deflate the balloon by carefully inserting a drinking straw into the balloon's auto-seal valve and then gently squeeze the balloon's helium out.

## 9. The warranty in USA and Canada:

Your U.S. Navy Blimp is warranted against any manufacturer's defects. A defective part will be replaced or repaired, with the same or similar model provided that the U.S. Navy Blimp have been operated according to the instructions and that a dated purchase receipt is provided. The warranty does not apply to any product which has been subject to abuse, misuse, and operation different than described in this manual, negligence, an accident or not observing the general precautions. Defects caused by tampering, unauthorized alterations or repairs, or other causes not arising out of defects in material or workmanship are not covered by this warranty. NOTE: The mylar balloon is NOT covered by warranty.

## 9a. The warranty in Europe and other countries:

The local distributor or retailer will provide a warranty. For further information please contact the retailer you purchased the product from or contact the importer (name is printed on the package).

### Tip!

Please try operating the units with FRESH BATTERIES before returning the product. Sometimes product seems to be defective, though weak batteries will cause poor performance.

Please contact Interactive Toy Concepts Ltd. before returning product to your retailer. Most problems can be dealt with either over the phone or via email.

Address for shipping products under warranty:

Interactive Toy Concepts Ltd.  
1192 Martingrove Road,  
Toronto, Ontario, Canada  
M9W 5M9  
Telephone - (416) 444-6873  
Fax - (416) 444-6879  
E-mail - info@interactivetoy.com  
WWW.INTERACTIVETOY.COM

Product must be returned in original packaging, with a proof of purchase and a brief explanation of the problem.

### Warning-

- Use only fresh non-rechargeable batteries of the same or equivalent type as recommended.
- Non-rechargeable batteries are not to be recharged.
- Batteries are to be inserted with the correct polarity.
- Exhausted batteries are to be removed from the toy.
- Batteries are to be removed if the toy will not be used for a few days.
- The supply terminals (battery contacts) are not to be short-circuited.